

# Filtri a Pressione



 **FANTONI**  
SERBATOI - DECANTATORI

<b>FILTRI A PRESSIONE</b> PRESSURE FILTERS	- STD A con Una Piastra - STD B con Due Piastre	<b>Altezza Cilindro</b> <b>Hc = 1.500mm</b>
---	--	--

<b>LINER DISPONIBILI</b> Resina Isoftalica O Resina Vinilestere
<b>FINITURA ESTERNA</b> Gelcoat Blu
<b>PRESSIONE DI ESERCIZIO DISPONIBILE:</b> PN 2,5 BAR PN 3 BAR PN 4 BAR
Nr. Ugelli: c.a. 70/m <sup>2</sup>
<b>Materiale Filtrante non Compreso nella Fornitura</b>

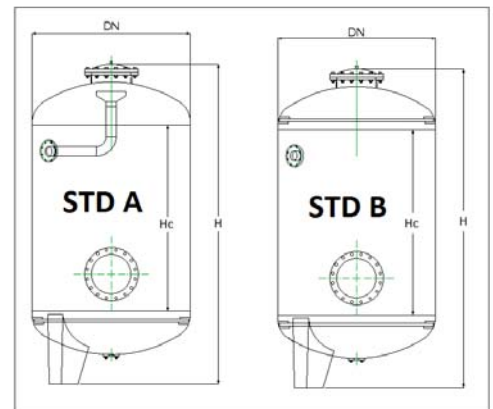
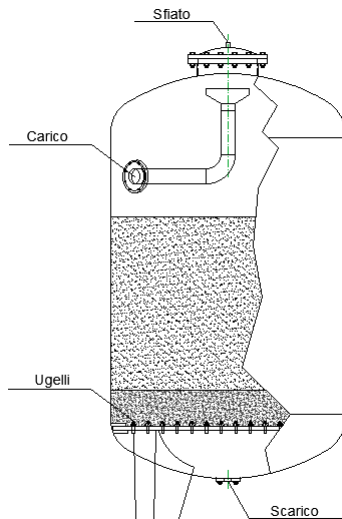

Diametro Diameter DN mm	Altezza Cilindro Hc mm	Altezza Totale H mm	Superficie Filtrante m <sup>2</sup>	Flangia Carico DN	Flangia Scarico DN	Sfiato	Ispezione Superiore DN	Ispezione Frontale DN
600	1500	2350	0,28	50	50	3/4"	150	400
700	1500	2350	0,38	50	50	3/4"	150	400
750	1500	2350	0,44	50	50	3/4"	150	400
800	1500	2400	0,5	65	65	1"	210	400
850	1500	2400	0,57	65	65	1"	210	400
900	1500	2500	0,63	65	65	1"	210	400
1000	1500	2500	0,78	65	65	1"	300	400
1100	1500	2500	0,95	80	80	1 1/2"	300	400
1200	1500	2500	1,13	80	80	1 1/2"	300	400
1250	1500	2600	1,22	80	80	1 1/2"	400	400
1400	1500	2600	1,54	80	80	1 1/2"	400	400
1500	1500	2600	1,76	100	100	2"	400	400
1600	1500	2700	2	100	100	2"	400	400
1800	1500	2750	2,54	100	100	2"	400	400
1900	1500	2750	2,83	100	100	2"	400	400
2000	1500	2800	3,14	125	125	2"	400	400
2200	1500	2800	3,45	125	125	2"	400	400
2400	1500	2850	4,52	125	125	2"	400	400

<b>FILTRI A PRESSIONE</b> PRESSURE FILTERS	- STD A con Una Piastra - STD B con Due Piastre	<b>Altezza Cilindro</b> <b>Hc = 2.000mm</b>
---	--	--

<b>LINER DISPONIBILI</b> Resina Isoftalica O Resina Vinilestere
<b>FINITURA ESTERNA</b> Gelcoat Blu
<b>PRESSIONE DI ESERCIZIO DISPONIBILE:</b> PN 2,5 BAR PN 3 BAR PN 4 BAR
Nr. Ugelli: c.a. 70/m <sup>2</sup>
<b>Materiale Filtrante non Compreso nella Fornitura</b>

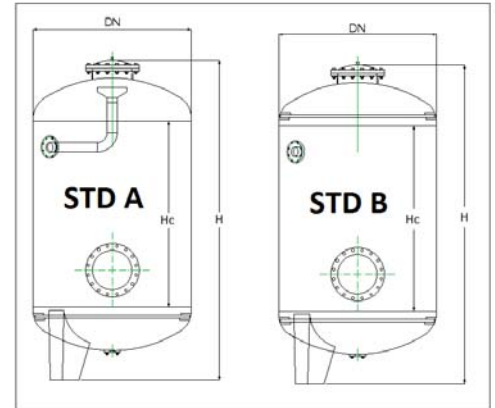
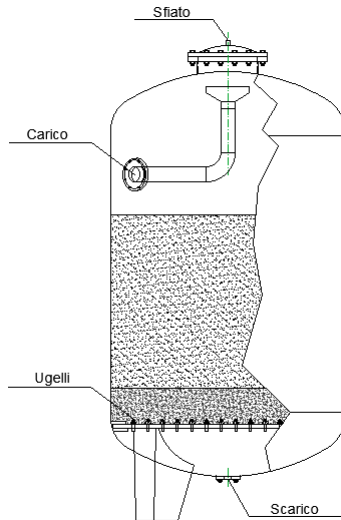

Diametro Diameter DN mm	Altezza Cilindro Hc mm	Altezza Totale H mm	Superficie Filtrante m <sup>2</sup>	Flangia Carico DN	Flangia Scarico DN	Sfiato	Ispezione Superiore DN	Ispezione Frontale DN
600	2000	2850	0,28	50	50	3/4"	150	400
700	2000	2850	0,38	50	50	3/4"	150	400
750	2000	2850	0,44	50	50	3/4"	150	400
800	2000	2900	0,5	65	65	1"	210	400
850	2000	2900	0,57	65	65	1"	210	400
900	2000	3000	0,63	65	65	1"	210	400
1000	2000	3000	0,78	65	65	1"	300	400
1100	2000	3000	0,95	80	80	1 1/2"	300	400
1200	2000	3000	1,13	80	80	1 1/2"	300	400
1250	2000	3100	1,22	80	80	1 1/2"	400	400
1400	2000	3100	1,54	80	80	1 1/2"	400	400
1500	2000	3100	1,76	100	100	2"	400	400
1600	2000	3200	2	100	100	2"	400	400
1800	2000	3250	2,54	100	100	2"	400	400
1900	2000	3250	2,83	100	100	2"	400	400
2000	2000	3300	3,14	125	125	2"	400	400
2200	2000	3300	3,45	125	125	2"	400	400
2400	2000	3350	4,52	125	125	2"	400	400

<b>FILTRI A PRESSIONE</b> PRESSURE FILTERS	- STD A con Una Piastra - STD B con Due Piastre	<b>Altezza Cilindro</b> <b>Hc = 2.500mm</b>
---	--	--

<b>LINER DISPONIBILI</b> Resina Isoftalica o Resina Vinilestere	
<b>FINITURA ESTERNA</b> Gelcoat Blu	
<b>PRESSIONE DI ESERCIZIO DISPONIBILE:</b>  PN 2,5 BAR PN 3 BAR PN 4 BAR	
Nr. Ugelli:  c.a. 70/m <sup>2</sup>	
<b>Materiale Filtrante non Compreso nella Fornitura</b>	

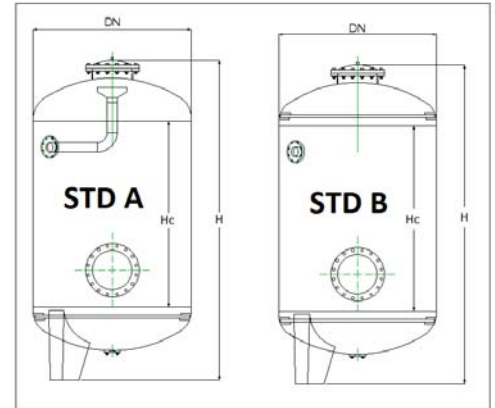
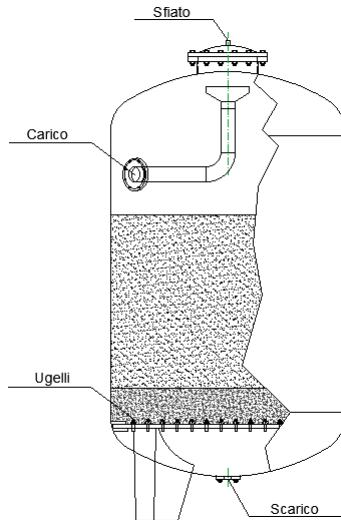

Diametro Diameter DN mm	Altezza Cilindro Hc mm	Altezza Totale H mm	Superficie Filtrante m <sup>2</sup>	Flangia Carico DN	Flangia Scarico DN	Sfiato	Ispezione Superiore DN	Ispezione Frontale DN
600	2500	3350	0,28	50	50	3/4"	150	400
700	2500	3350	0,38	50	50	3/4"	150	400
750	2500	3350	0,44	50	50	3/4"	150	400
800	2500	3400	0,5	65	65	1"	210	400
850	2500	3400	0,57	65	65	1"	210	400
900	2500	3500	0,63	65	65	1"	210	400
1000	2500	3500	0,78	65	65	1"	300	400
1100	2500	3500	0,95	80	80	1 1/2"	300	400
1200	2500	3500	1,13	80	80	1 1/2"	300	400
1250	2500	3600	1,22	80	80	1 1/2"	400	400
1400	2500	3600	1,54	80	80	1 1/2"	400	400
1500	2500	3600	1,76	100	100	2"	400	400
1600	2500	3700	2	100	100	2"	400	400
1800	2500	3750	2,54	100	100	2"	400	400
1900	2500	3750	2,83	100	100	2"	400	400
2000	2500	3800	3,14	125	125	2"	400	400
2200	2500	3800	3,45	125	125	2"	400	400
2400	2500	3850	4,52	125	125	2"	400	400





**Fantoni & Luciani S.r.l. Unip.**

Via Benaco, 1 – 25081 Bedizzole (BS)

Tel. +39 030 67 40 57

E-mail: [info@fantoniserbatoi.com](mailto:info@fantoniserbatoi.com) [tecnico@fantoniserbatoi.it](mailto:tecnico@fantoniserbatoi.it)

Web: [www.fantoniserbatoi.it](http://www.fantoniserbatoi.it)